

CGS-450.9-20K

Nuovo carrello per cancelli autoportanti pesanti.
Portata **20.000 Kg**, per aperture fino a **30 metri**

CGS-450.9-20K

Carrello a 9 ruote per cancelli autoportanti pesanti.
Portata **20.000 Kg**, per aperture fino a **30 metri**



CARATTERISTICHE

- Corpo monoblocco in acciaio da 35 mm
- I cuscinetti schermati ad alta capacità garantiscono prestazioni di carico elevate
- Tutti i componenti sono in acciaio di alta qualità
- La ruota centrale di allineamento assicura stabilità durante il movimento
- Viti di regolazione per la planarità.
- Base robusta con asole di regolazione

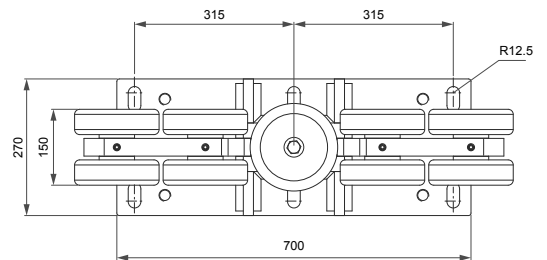
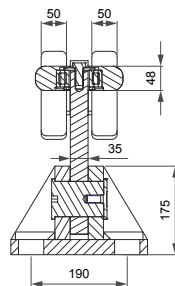
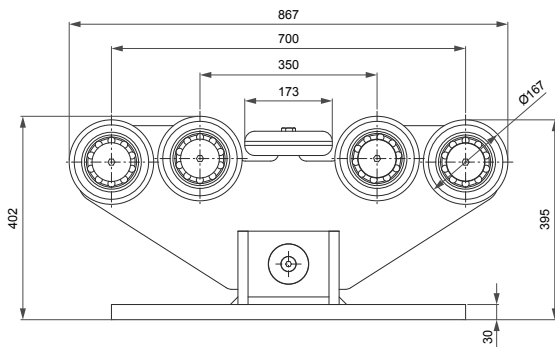

CODE	ART.	Size	Box info	
			Pcs per pack	Kg
10130070 001	CGS-450.9-20K	Grande	1	198

Finitura: Zincato

Per il calcolo strutturale della fondazione (FA, FB, FH), interasse tra i carrelli (I) e tipologia di ancoraggio si consiglia di rivolgersi ad uno studio di progettazione. La lunghezza totale del cancello (LT) dipende dall'interasse I calcolato.

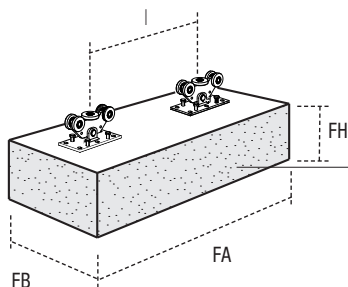

FONDEMENTA

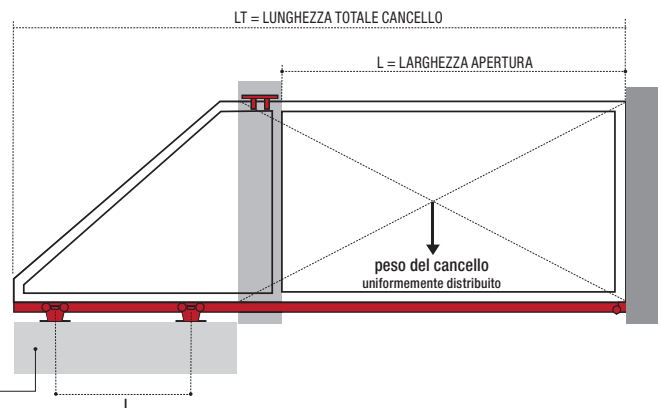

CGS-495-20K

Monorotaia per cancelli auto-portanti

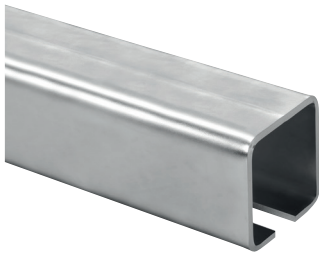

CODE	ART.	Lunghezza mm	Finitura	Box info	
				Pcs per pack	Kg
10207040	CGS-495-20K	3000	Grezzo	1	195

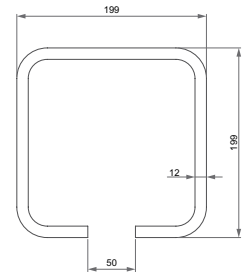

CGS-496-20K

Incontro inferiore a fissare



CODE	ART.	Box info	
		Pcs per pack	Kg
10705520 001	CGS-496-20K	1	9,5

Finitura: Zincato

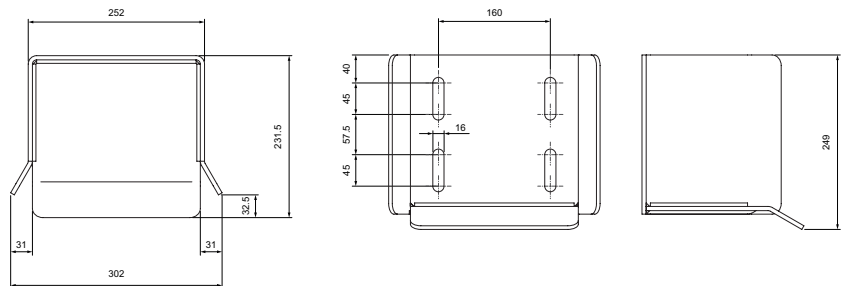

CGS-497-20K

Ruota terminale per monorotaia



CODE	ART.	Box info	
		Pcs per pack	Kg
10705020 001	CGS-497-20K	2	23

Finitura: Zincato

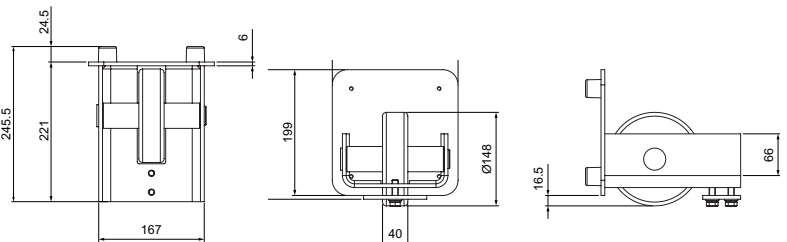

CGS-499

Piastra guida per cancelli scorrevoli e autoportanti



CODE	ART.	Capacity Fmax	Box info	
			Pcs per pack	Kg
11310401 001	CGS-499	500 Kg	2	4

Finitura: Zincato

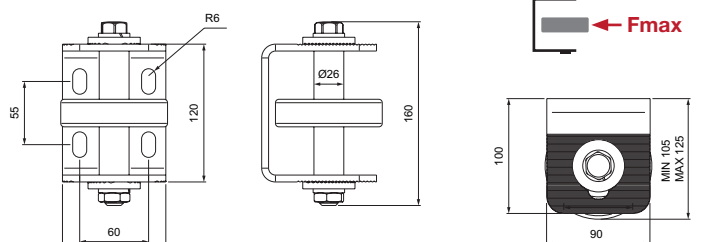

Gate innovation made in Comunello

 **COMUNELLO GATE**

FRATELLI COMUNELLO S.P.A.

Via Cassola, 64 - C.P. 79

36027 Rosà, Vicenza, Italy

Tel. +39 0424 585111 Fax +39 0424 533417

info@comunello.it www.comunello.com