

BORDER 400

ELECTROMECHANICAL BARRIER
FOR RESIDENTIAL, INDUSTRIAL
OR PUBLIC USE

Life
made
easy

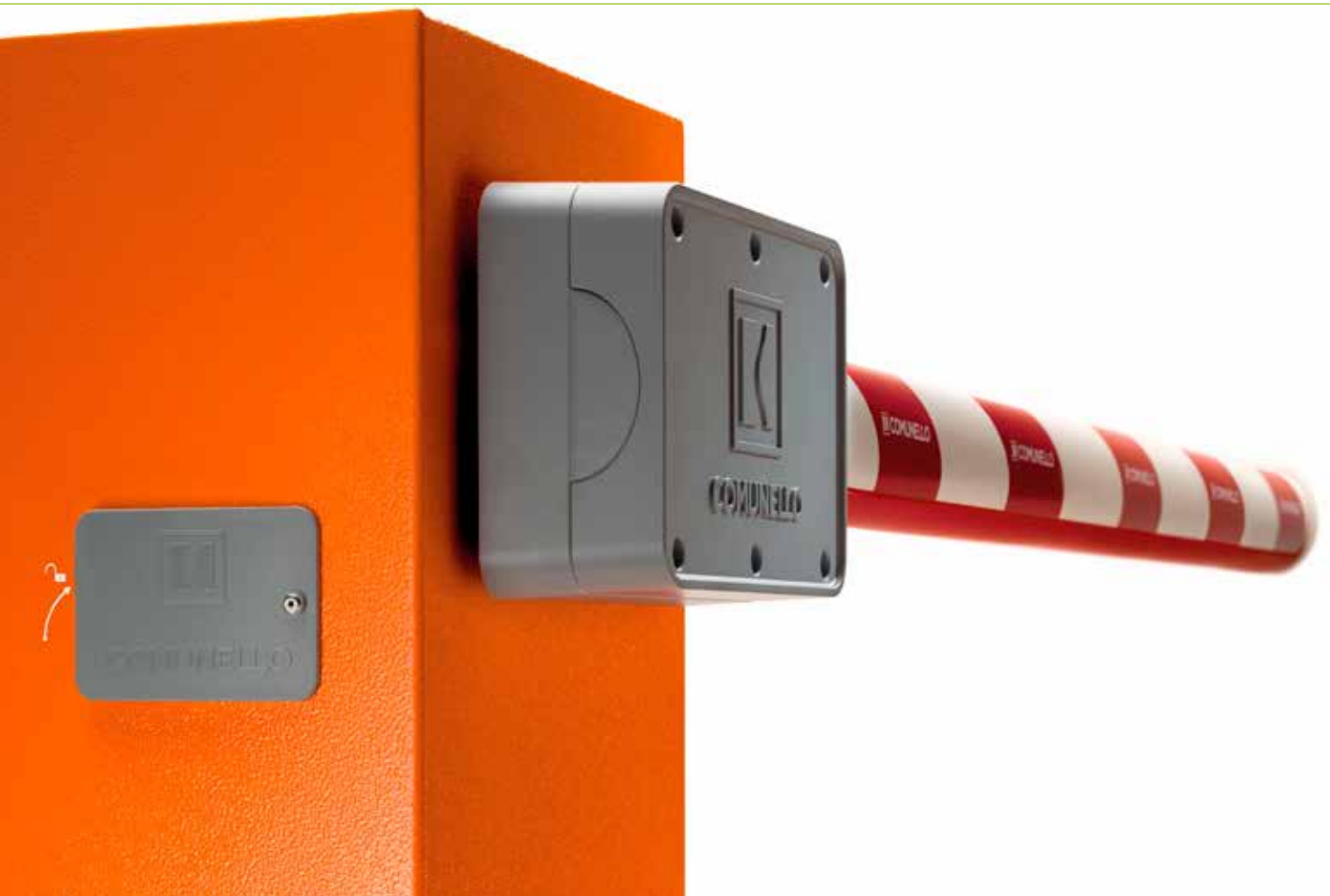

BORDER

up to 4m beam

Manual unlocking system available from both sides by aluminium handle

Robust ambidextrous bar support in die-cast aluminium



Light and durable elliptical section beam

Robust steel frame with protective treatment

Start of the slowdown phases adjustable by dip-switches. Thanks to the adjustable cams it is possible to change the slowdown starting points according to the needs.

Mechanical stop adjustment by one screw

Spherical self-lubricating eyelet-fixed spring for smoother, wear reducing movement

Easily accessible and extractable built-in control board for appropriate programming

A single spring can be fixed in 2 different holes of the spring tensioning arm according to the different bar length



Depending on the length of the beam and relative accessories, the AC-541 spring must be fixed to one of the holes of the spring-tightening arm according to the table and diagram below.

SPRING AC-541



SPRING POSITIONING AC-541

| ROD LENGTH | 2 m | 3 m | 4 m |
|-----------------------------|-----|-------|-----|
| BEAM | - | 1-2 * | 2 |
| BEAM WITH PROTECTIVE RUBBER | 1 | 1-2 * | 2 |
| BEAM WITH MOBILE SUPPORT | 1 | 2 | 2 |

* The spring could be fixed to both holes with a proper regulation

SPRING-TIGHTENING ARM

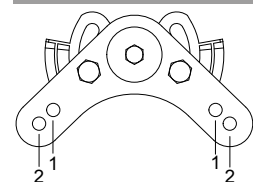

Every single product is duly tested at the end of each assembly line

TECHNICAL FEATURES

| | BORDER 400 24V |
|------------------------|----------------|
| Power supply | 230 VAC |
| Motor power supply | 24 VDC |
| Power consumption | 150 W |
| Current input | 6,2 A |
| Torque | 100 Nm |
| Duty cycle | Intensive use |
| Protection rating (IP) | IP44 |
| Insulation class | 2 |
| Working temperature | -20°C / +50°C |

DIMENSIONS (mm)

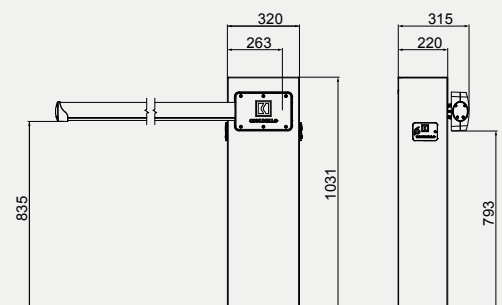

For beams up to 4 m in length





OFFICIAL DEALER:

 **COMUNELLO**
AUTOMATION

AUTOMATION FOR GATES, DOORS AND BARRIERS

FRATELLI COMUNELLO S.P.A.

HEADQUARTERS

Via Zarpellon, 33

36027 San Giuseppe di Cassola, Vicenza, Italy

Tel. +39 0424 585111 Fax +39 0424 533417

info@comunello.it www.comunello.com

REGISTERED OFFICE

Via Cassola,64 - C.P.79

36027 Rosà, Vicenza, Italy

Tel. +39 0424 585111 Fax +39 0424 533417

info@comunello.it www.comunello.com