

CONDOR 500

AUTOMATION
FOR SWING GATES
24 VDC AND 230 VAC

Life
made
easy



CONDOR 500

Technical features

Manual unlocking system with key and aluminium handle. Possibility of remote cable operation.

Anti-shearing arm in galvanized iron available arms with mechanical block



Actuator support bracket in galvanized steel included



Every single product is duly tested at the end of each assembly line



Integrated electromechanical limit switches

DIMENSIONS (mm)

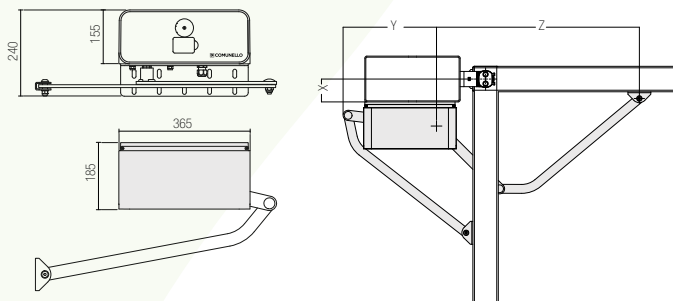

X	Z	Y
50	554	535
100	555	635
150	555	535
200	555	690

OPERATING LIMITS CONDOR 500

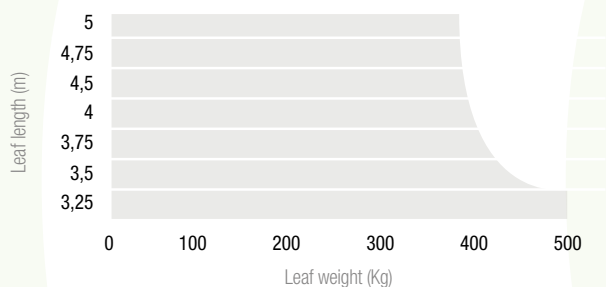

AC-102-103-104

Ambidextrous arms in painted steel with locking system

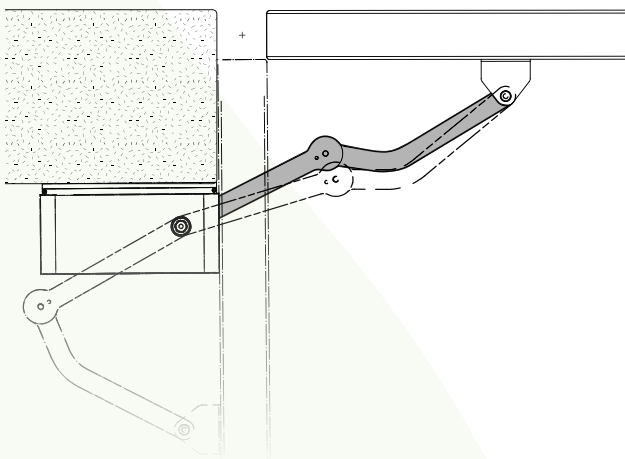

L = 385mm + 330mm



L = 503mm + 430mm



L = 238mm + 620mm

Technical features

	CONDOR 500 24V	CONDOR 500 230V
Voltage	24 VDC	230 VAC 50 Hz
Power consumption	150 W	280 W
Max. absorption	6,5 A	1,2 A
Max. thrust	330 Nm	440 Nm
Duty cycle	Intensive use	50%
Protection degree (IP)	IP44	IP44
Insulation class	2	1 (earthing)
Working temperature	-20°C / +50°C	-20°C / +50°C
No-load speed	0,15 rad/sec	0,1 rad/sec
Weight	12 kg	12 kg



CONDOR 500

24V **230V**

up to 5 m

OFFICIAL DEALER:



AUTOMATION FOR GATES, DOORS AND BARRIERS

FRATELLI COMUNELLO S.P.A.

HEADQUARTERS

Via Zarpellon, 33

36027 San Giuseppe di Cassola, Vicenza, Italy

Tel. +39 0424 585111 Fax +39 0424 533417

info@comunello.it www.comunello.com

REGISTERED OFFICE

Via Cassola,64 - C.P.79

36027 Rosà, Vicenza, Italy

Tel. +39 0424 585111 Fax +39 0424 533417

info@comunello.it www.comunello.com