

FORT

ACTUATOR FOR
SLIDING GATES
VERSIONS 230V AND 24V

Life
made
easy



FORT

Technical features



Robust carter with anti UV treatment

Release for manual operation with key and integrated aluminum lever

DIMENSIONS (mm)

FORT 600-700-1000-1500:

A=320 - B=231

FORT 400-500:

A=341 - B=280

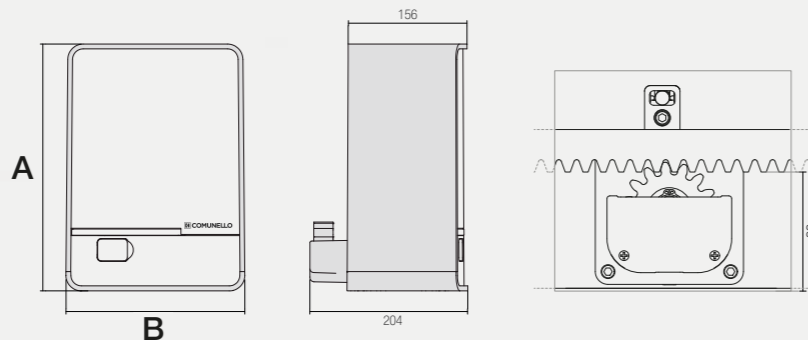

On-board control unit with integrated receiver. Basic, High Performance versions available, with or without Encoder

Prewired pad printed terminals

Available with mechanical or magnetic limit switches versions



Every single product is duly tested at the end of each assembly line

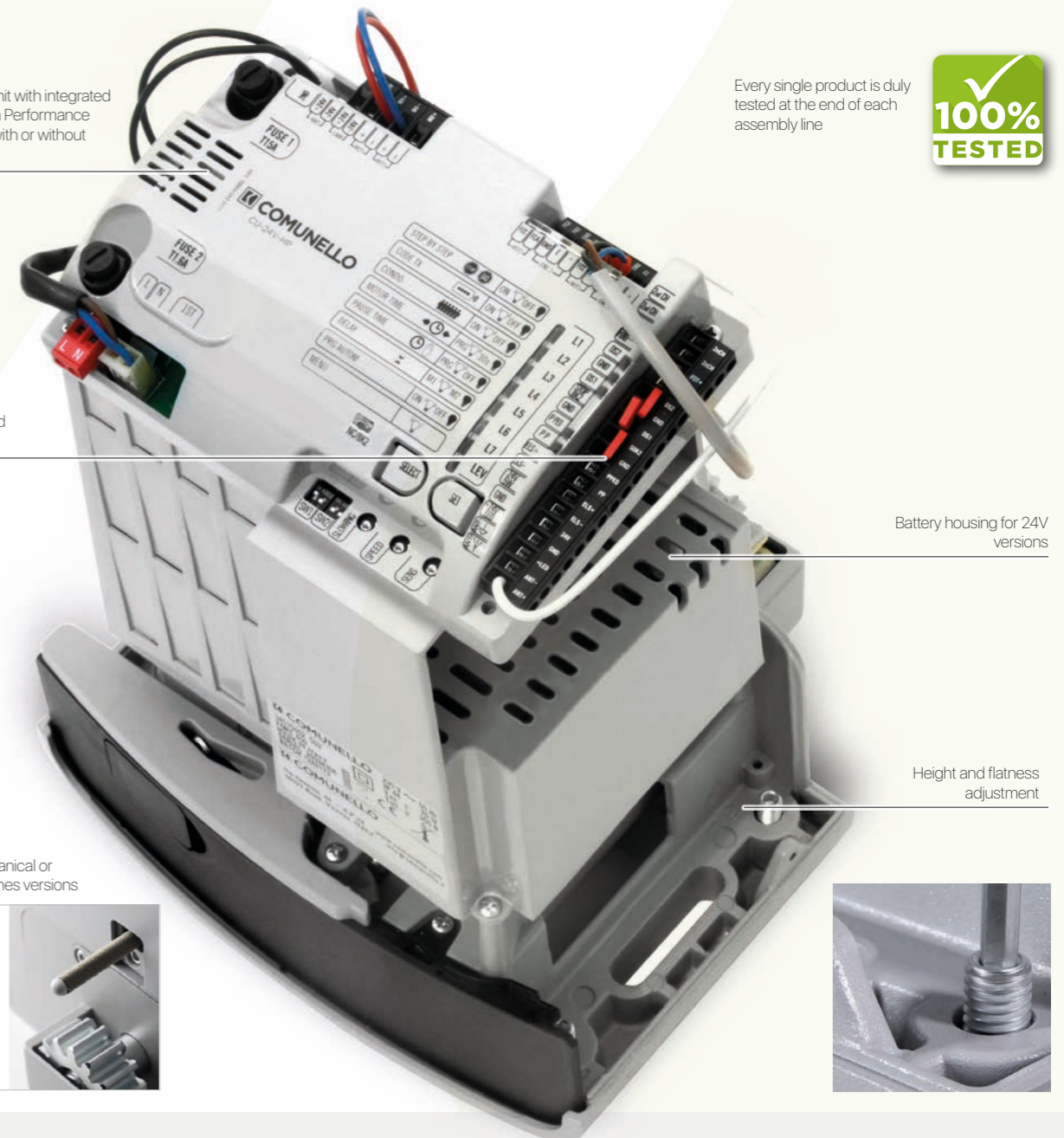

Battery housing for 24V versions

Height and flatness adjustment



TECHNICAL CHARACTERISTICS

	FORT 400 24V	FORT 500 230V	FORT 600 24V	FORT 700 230V	FORT 1000 24V	FORT 1000 230V	FORT 1500 230V
Voltage	230 VAC 50 Hz	230 VAC 50 Hz	230 VAC 50 Hz/50 Hz	230 VAC 50 Hz	230 VAC 50 Hz	230 VAC 50 Hz	230 VAC 50 Hz
Operating power supply	24 VDC	230 VAC	24 VDC	230 VAC	24 VDC	230 VAC	230 VAC
Power consumption	70 W	280 W	110 W	300 W	150 W	340 W	460 W
Max. absorption	3,0 A	1,2 A	5,0 A	1,3 A	6,2 A	1,5 A	2,0 A
Max. thrust	350 N	450 N	550 N	600 N	900 N	900 N	1400 N
Duty cycle	Intensive use	0,5	Intensive use	0,5	Intensive use	0,5	0,5
Protection degree (IP)	IP44	IP44	IP44	IP44	IP44	IP44	IP44
Insulation class	1 (earthing)	1 (earthing)	2	1 (earthing)	2	1 (earthing)	1 (earthing)
Working temperature	-20°C / +50°C	-20°C / +50°C	-20°C / +50°C	-20°C / +50°C	-20°C / +50°C	-20°C / +50°C	-20°C / +50°C
Max. gate weight	400 Kg	500 Kg	600 Kg	700 Kg	1000 Kg	1000 Kg	1500 Kg
Rack module	M4	M4	M4	M4	M4	M4	M4
Speed	0,17 m/s	0,17 m/s	0,17 m/s	0,17 m/s	0,17 m/s	0,12 m/s	0,12 m/s
Weight	8,9 Kg	9,9 Kg	10,6 Kg	12 Kg	12 Kg	12,4 Kg	12,6 Kg



OFFICIAL DEALER:

 **COMUNELLO**
AUTOMATION

AUTOMATION FOR GATES, DOORS AND BARRIERS

FRATELLI COMUNELLO S.P.A.

HEADQUARTERS

Via Zarpellon, 33

36027 San Giuseppe di Cassola, Vicenza, Italy

Tel. +39 0424 585111 Fax +39 0424 533417

info@comunello.it www.comunello.com

REGISTERED OFFICE

Via Cassola,64 - C.P.79

36027 Rosà, Vicenza, Italy

Tel. +39 0424 585111 Fax +39 0424 533417

info@comunello.it www.comunello.com