

 **COMUNELLO**
AUTOMATION

CONDOR 500

AUTOMAÇÃO PARA
PORTÕES DE BATENTE
24VDC E 230VAC

Life
made
easy



CONDOR 500

Características técnicas

Desbloqueio para acionamento manual com chave e cabo de alumínio. Preparado para desbloqueio por corda remota

Braço anti-cisalhamento em aço galvanizado
Braços com trava mecânica disponíveis



Suporte do atuador em aço galvanizado incluído



Fins de curso externo eletromecânicos integrados



Cada produto é testado regularmente no final da linha de montagem

DIMENSÕES (mm)

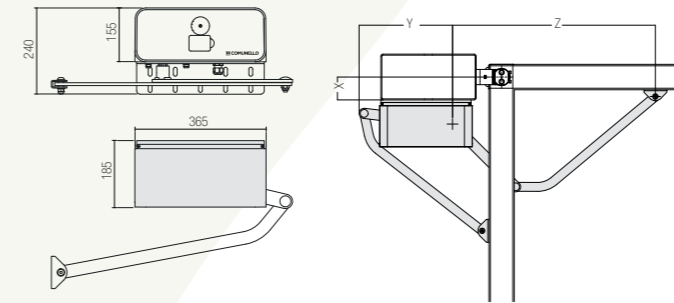

X	Z	Y
50	554	535
100	555	635
150	555	535
200	555	690

LIMITES DE USO CONDOR 500

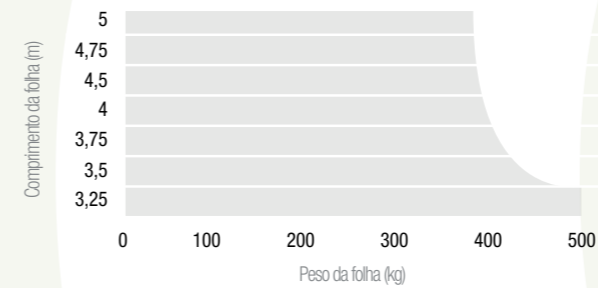

AC-102-103-104

Braços ambidestros em aço pintado com fechadura

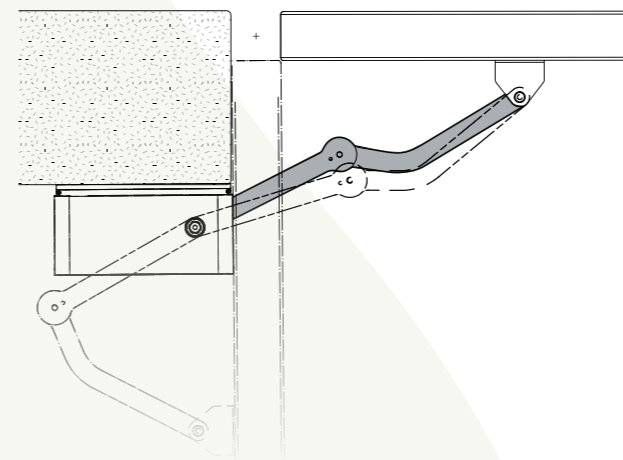

Características técnicas

	CONDOR 500 24V	CONDOR 500 230V
Alimentação	24 VDC	230 VAC 50 Hz
Alimentação do motor	150 W	280 W
Absorção máx.	6,5 A	1,2 A
Impulso máx.	330 Nm	440 Nm
Ciclo de trabalho	Uso intensivo	50%
Grau de proteção (IP)	IP44	IP44
Classe de isolamento	2	1 (ligação à terra)
Temp. de operação	-20°C / +50°C	-20°C / +50°C
Velocidade sem carga	0,15 rad/sec	0,1 rad/sec
Peso	12 kg	12 kg



CONDOR 500 24V 230V
até 5m



L = 385mm + 330mm



L = 503mm + 430mm



L = 238mm + 620mm

CONCESSIONÁRIO OFICIAL:



AUTOMATION FOR GATES, DOORS AND BARRIERS

FRATELLI COMUNELLO S.P.A.

HEADQUARTERS

Via Zarpellon, 33
36027 San Giuseppe di Cassola, Vicenza, Italy
Tel. +39 0424 585111 Fax +39 0424 533417
info@comunello.it www.comunello.com

REGISTERED OFFICE

Via Cassola,64 - C.P.79
36027 Rosà, Vicenza, Italy
Tel. +39 0424 585111 Fax +39 0424 533417
info@comunello.it www.comunello.com