

Life  
made  
easy

## LIMIT 800

ELECTROMECHANICAL BARRIER  
FOR RESIDENTIAL, INDUSTRIAL  
OR PUBLIC USE



# LIMIT 800

up to 8m beam



Possibility to install a LED signal light on board

Robust ambidextrous beam support in shaped steel

Possibility to install, along the beam sides, beam strip LED for crossing-light version or with white light

Manual key and fold-away emergency release lever

Robust steel frame with protective treatment

Easily accessible control unit for a proper programming

Adjustable screws allow a more precise mechanical stop

Easy adjustment of the limit switches by means of the special screw in the tension plate

Available single spring or double spring depending on the size of beam and accessories



**ASSEMBLING BEAM, SPRING CHOICE AND BALANCE**

**LENGTH**

	6,00	6,50	7,00	7,50	8,00
Beam with joint and plug	●	●	●	●	●
Beam with joint, plug and strip led	●	●	●	●	●
Beam with joint, plug and protective rubbers	●	●	●	●	●
Beam with joint, plug, protective rubbers and strip led	●	●	●	●	●
Beam with joint, plug and mobile support	●	●	●	●	●
Beam with joint, plug, mobile support and strip led	●	●	●	●	●
Beam with joint, plug, mobile support, strip led and protective rubbers	●	●	●	●	●
Beam with joint, plug and aluminum skirt	●	●	●	●	●
Beam with joint, plug, aluminum skirt and strip led	●	●	●	●	●
Beam with joint, plug, aluminum skirt, strip led and mobile support	●	●	●	●	●

● SPRING AC 540 ● Double SPRING AC 550



Every single product is duly tested at the end of each assembly line

**TECHNICAL FEATURES**

	LIMIT 800 24V
Power supply	230 VAC
Motor power supply	24 VDC
Power consumption	150 W
Current input	6,2 A
Torque	300 Nm
Duty cycle	Intensive use
Protection rating (IP)	IP44
Insulation class	2
Working temperature	-20°C / +50°C

**DIMENSIONS (mm)**

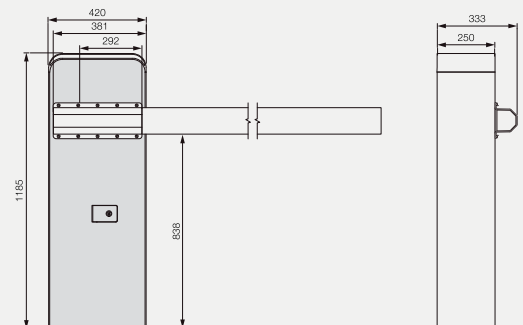

For beams up to 7 m (3+4 m) and up to 8 m (4+4 m)



For beams up to 10/16 m





OFFICIAL DEALER:

 **COMUNELLO**  
AUTOMATION

AUTOMATION FOR GATES, DOORS AND BARRIERS

FRATELLI COMUNELLO S.P.A.

HEADQUARTERS

Via Zarpellon, 33

36027 San Giuseppe di Cassola, Vicenza, Italy

Tel. +39 0424 585111 Fax +39 0424 533417

info@comunello.it www.comunello.com

REGISTERED OFFICE

Via Cassola,64 - C.P.79

36027 Rosà, Vicenza, Italy

Tel. +39 0424 585111 Fax +39 0424 533417

info@comunello.it www.comunello.com